

MODEL 3J-LP SWIVEL WITH ADJUSTABLE PACKING

SPECIFICATIONS

STANDARD 20XV-04NHM PACKING AND 20XV-05NHM WEAR BUSHING PARALLEL GROUND FOR MAXIMUM LIFE

2-1/2" INSIDE DIAMETER

VITON PACKING SEALS AVAILABLE

CAPACITIES FOR 100 R.P.M. AT 3,000 HOURS

PULLDOWN CAPACITY	PULLBACK CAPACITY	WORKING PRESSURE	DIAMETER WATERCOURSE
8,638 LBS	8,638 LBS	375 P.S.I.	1.93

WEIGHT AND DIMENSIONAL DATA

LENGTH INCHES	WEIGHT POUNDS	LOWER CONNECTION	HOSE CONNECTION
13.5"	37 LBS W/BAIL	2" NPT LH OR RH	2 NPT

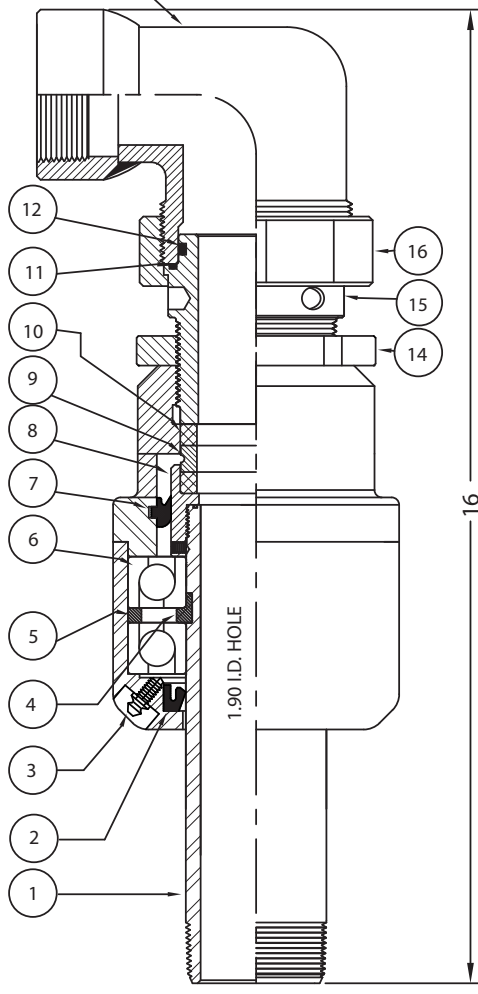
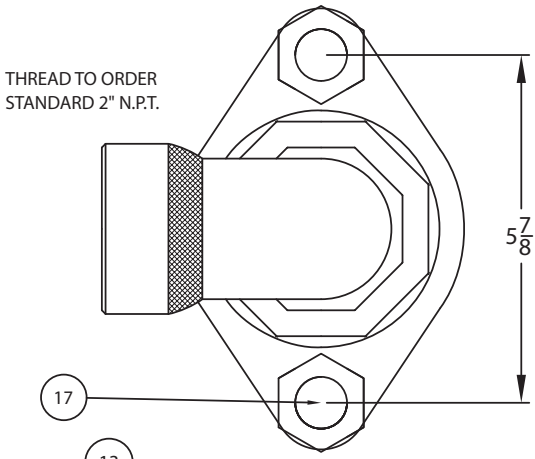

PARTS LIST FOR 3J-LP WITH ADJUSTABLE PACKING

ITEM	PART NO.	QTY	DESCRIPTION
1	136-005G	1	SPINDLE
2	3J-07	1	GREASE SEAL 470565
3	1/4-28GF	1	GREASE FITTING
4	3J-010	1	SPLIT RING
5	3J-06	1	BEARING SPACER
6	3J-09	2	BEARING
7	5EL-07NHM	1	GREASE SEAL
8	3JLP-006	1	SPINDLE NUT
9	5EL-04NHM	1	WEAR BUSHING
10	5EL-03NHM	2	PACKING RING
11	136-147	1	147-O-RING
12	136-229	1	229-O-RING
13	136-210A	1	2"-90 GOOSENECK
14	136	1	LOCK NUT
15	136-210	1	WASH PIPE
16	136-211B	1	UNION NUT
17	3J-002	1	ALL THREAD W/NUTS

BAIL MADE FROM HEAT-TREATED ALLOY STEEL (GRADE B-7)

NOTE: LOW-PRESSURE PACKING INTERCHANGEABLE WITH KING OIL TOOLS 5-EL SWIVEL ASSEMBLY.