

EXPERIENCE PERFOR

THE TOP HEAD DRIVES ILLUSTRATED HAVE NUMEROUS MOTORS THAT CAN BE USED DEPENDING UPON THE TORQUE AND SPEEDS REQUIRED.

EACH HYDRAULIC MOTOR IS DIFFERENT IN DISPLACEMENT, WHICH GOVERNS THE TORQUES AND SPEEDS AND HAS TO BE SIZED TO THE DESIRED REQUIREMENTS.

2000 CHAR LYNN HYDRAULIC MOTOR

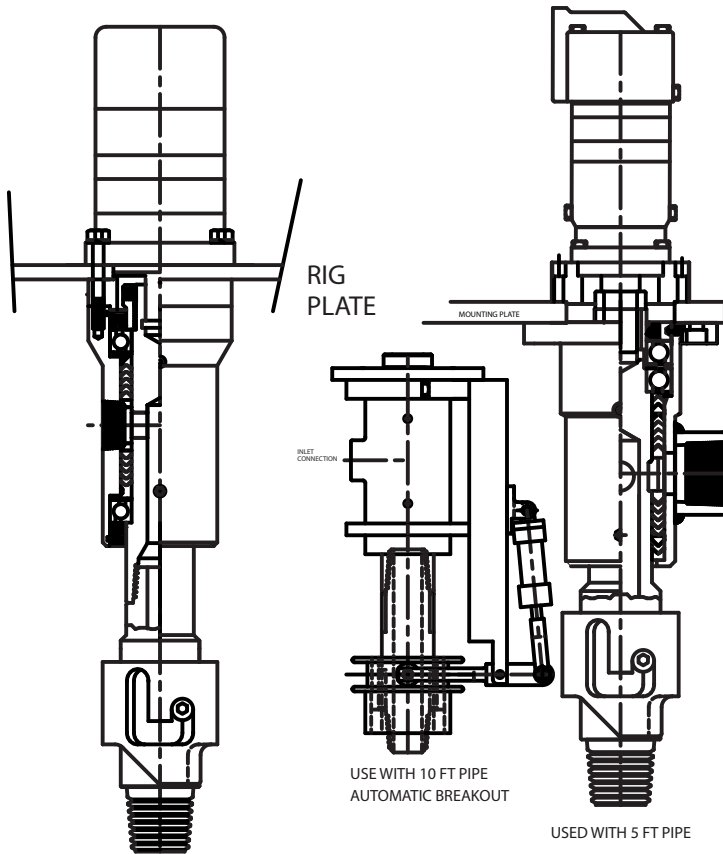

MODEL 200 ROTARY HEAD WITH MANUAL BREAKOUT HYDRAULIC MOTOR

MARK I-II-III

MARK I Rotary Head Data:

PULLDOWN CAPACITY:	4,800 LBS
PULLBACK CAPACITY:	4,800 LBS
WATERCOURSE STANDARD	1 3/16"
WORKING PRESSURE	750 P.S.I.

MARK II Rotary Head Data:

PULLDOWN CAPACITY:	5,872 LBS
PULLBACK CAPACITY:	5,872 LBS
WATERCOURSE STANDARD	1 3/16 I.D.
WORKING PRESSURE	750 P.S.I.

MARK III Rotary Head Data:

PULLDOWN CAPACITY:	5,873 LBS.
PULLBACK CAPACITY:	9,513 LBS.
WATERCOURSE STANDARD	1 3/16 I.D.
WORKING PRESSURE	750 P.S.I.